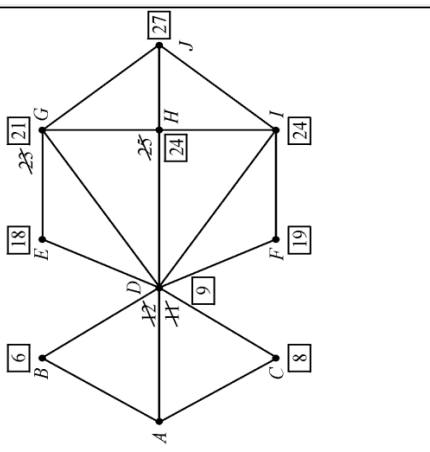
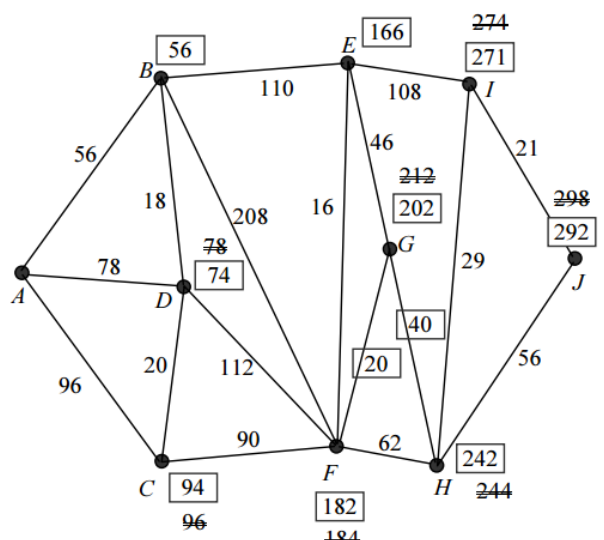

<p>4 (a)</p>  <p>Route ACDEGJ</p>	<p>M1 A1 A1F A1F B1 B1</p>	<p>6</p>	<p>SCA At D At G (D + 12) At H (D + 15) For 27 at J</p>
---	---	----------	---

Q	Solution	Marks	Total	Comments
<p>3(a)</p>  <p>Route: ABFGHIJ</p>	<p>To E, $74 + x$ $74 + x = 156$ $x = 82$</p> <p>Route: ABDEFGHIJ</p>	<p>M1 A1 A1F A1F A1F A1 B1 M1 A1F B1</p>	<p>7 3</p>	<p>s.c.a for D for F for G for H for J as 292 c.a.o for part (a)</p>
Total			10	

Q	Solution	Marks	Total	Comments
5 (a)		M1 A1 A1 A1F A1F B1 × 3	 8	SCA Working back from <i>N</i> For <i>K</i> For <i>G, H, I</i> For <i>D, E, F</i>
	(b) Route A = <i>ADHGKMN</i> B = <i>BEHGKMN</i> C = <i>CFEHGKMN</i>	B1 × 3	3	
Total			11	